

WEIGHING ASSEMBLY HM-2-401



Assembled with H2F

Capacity	Part number
1t-5t	HM-2-401-1/5t
10t	HM-2-401-10t
15t	HM-2-401-15t
20t	HM-2-401-20t
30t	HM-2-401-30t
50t	HM-2-401-50t

Features

- ◆ Restrict horizontal movement
- ◆ Anti-turnover
- ◆ Correct dislocation automatically
- ◆ Compact structure, simple installation

Specifications

Ultimate overload	150%FS
Maximum horizontal displacement	±3mm
Maximum force against retroflexion	50%FS
Maximum force against slide	50%FS
Material	Alloy steel

Outline Dimensions in mm(inches)

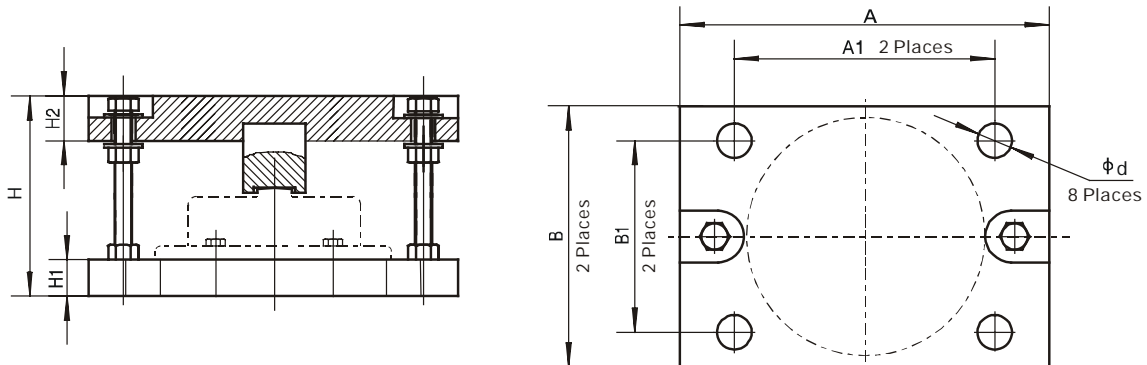

Dimensions Capacity(t)	A	A 1	B	B 1	H	H 1	H 2	d
1 - 5	228 (8.98)	168 (6.61)	170 (6.69)	110 (4.33)	112 (4.41)	20 (0.79)	27 (1.06)	17.5 (0.69)
10	260 (10.24)	200 (7.87)	200 (7.87)	140 (5.51)	143 (5.63)	25 (0.98)	31 (1.22)	20 (0.79)
15	294 (11.57)	234 (9.21)	234 (9.21)	174 (6.85)	163 (6.42)	30 (1.18)	37 (1.46)	20 (0.79)
20	320 (12.60)	260 (10.24)	260 (10.24)	200 (7.87)	167 (6.57)	30 (1.18)	37 (1.46)	20 (0.79)
30	330 (12.99)	270 (10.63)	270 (10.63)	210 (8.27)	182 (7.17)	35 (1.38)	47 (1.85)	23 (0.91)
50	364 (14.33)	294 (11.57)	294 (11.57)	224 (8.82)	202 (7.95)	40 (1.57)	55 (2.17)	27 (1.06)