

WEIGHING ASSEMBLY HM-14-401

Capacity	Part number
10t-50t	HM-14-401-10/50t



Alloy steel, assembled with HM14C or BM14C

Features

- ◆ Restrict horizontal movement
- ◆ Anti- turnover
- ◆ Correct dislocation automatically
- ◆ Compact structure, easy installation

Specifications

Ultimate overload	150%FS
Maximum force against retroflexion	50KN
Maximum force against slide	50KN
Maximum horizontal displacement	54mm

Outline Dimensions in mm(inches)

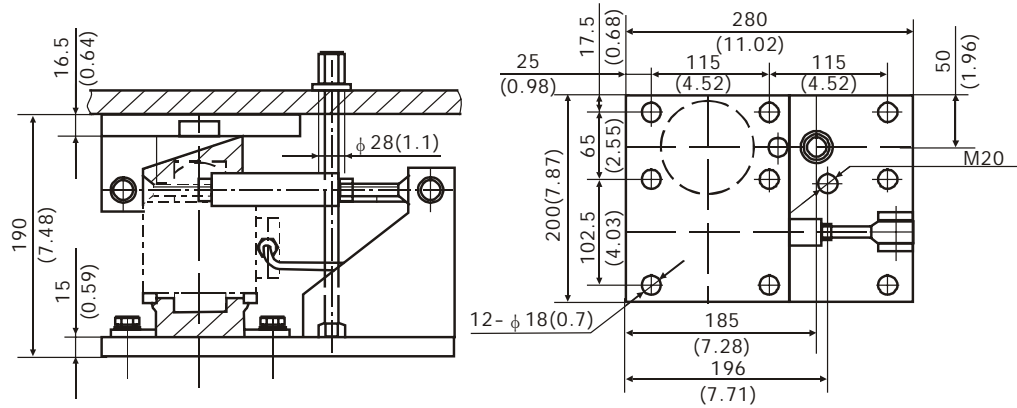

Installation

