

WEIGHING ASSEMBLY HL-3-004



Assembled with S-type load cell.

Capacity	Part number
25kg-50kg	HL-3-004-25/50kg
100kg	HL-3-004-100kg
200kg-300kg	HL-3-004-200/300kg
500kg-1.5t	HL-3-004-500kg/1.5t
2t-5t	HL-3-004-2/5t

Applications

- ◆ Conversion of mechanical scales
- ◆ Crane scales
- ◆ Packaging scales
- ◆ Hopper and tank scales

Outline Dimensions in mm(inches)

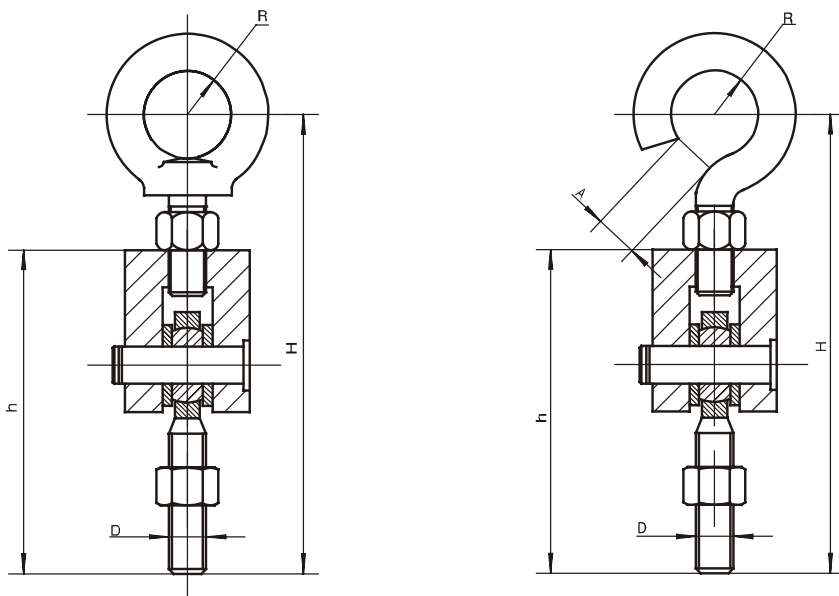

Capacity	Dimensions	D	H	R	A	h
25-50kg	M8	117 (4.61)	14 (0.55)	18 (0.71)	79 (3.11)	
100kg	M10	123 (4.89)	14 (0.55)	18 (0.71)	85 (3.35)	
200-300kg	M12	129 (5.07)	14 (0.55)	18 (0.71)	91 (3.58)	
500kg	M12	138 (5.43)	17 (0.67)	0	95 (3.74)	
750-1500kg	M12	138 (5.43)	17 (0.67)	0	95 (3.74)	
2t-5t	M20x1.5	/	/	0	135 (5.31)	